



**HEADQUARTER:**  
**Zecchetti s.r.l.** - Via Galileo Galilei, 1-1A  
42027 Montecchio Emilia (Reggio Emilia) Italy  
Tel. +39-0522.867411 - Fax +39-0522.866034  
E-mail: [sales@zecchetti.it](mailto:sales@zecchetti.it)  
Web-site: [www.zecchetti.it](http://www.zecchetti.it)

**U.S.A.:**  
**Zecchetti U.S.A.** Located in Florida,  
683 Main Street Suite "A"  
Safety Harbor - 34695 FL  
Phone 727-725-1968 / Fax. 727-725-9259  
E-mail: [zusa@tampabay.rr.com](mailto:zusa@tampabay.rr.com)



## Zecchetti & the PET

Zecchetti s.r.l. is a privately owned corporation (LLC), founded in 1960. The firm currently has **70 employees** organized in the activities of sales, product design, machine assembly, testing, installation, and post-sales service for all the company's product lines. The bulk of the products are manufactured by independent subcontractors that operate the surrounding areas.

This system of organization and cooperation has proven effective in producing over **3000 palletizing and depalletizing installations in the past 40 years** with an unrivalled level of quality, flexibility and design. The business growth of the last 4-5 years, is the result of a "Global Market" policy started years ago, necessitating an increase in both personnel and the facilities. In December 1999 Zecchetti moved to a new, bigger facility. 11.000 m<sup>2</sup> of workshop are now available to allow build-up, for pre-shipping tests, a considerable number of lines at the same time.

**Zecchetti**



1960 - 2001

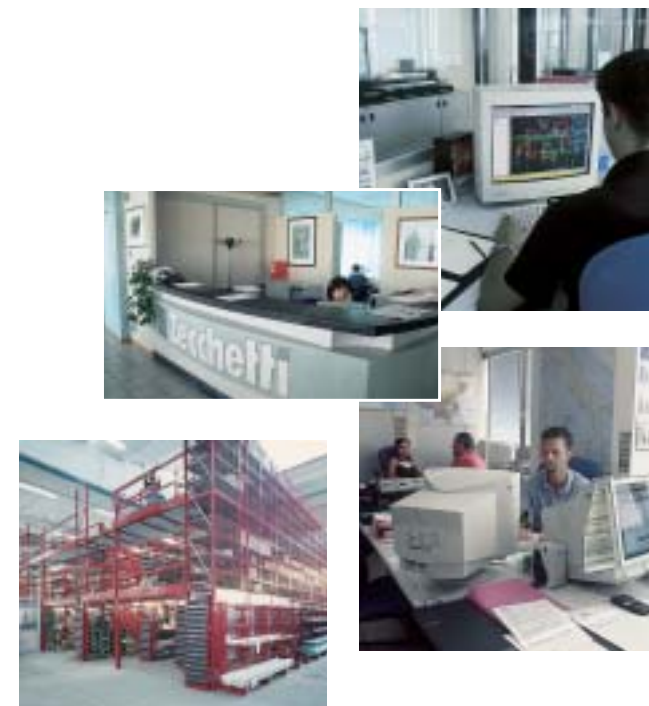

Study...Design ...Manufacturing...of Complete Lines.



A modern laboratory, fully equipped with the latest instruments, enables Zecchetti to test new Technologies and to carry out simulations on machine parts for rapid customer back-up in case of field problems.

Starting in our offices - and continuing through engineering, fabrication, installation - Zecchetti provides the best solution for any kind of production. New ideas and technologies as well as the expertise of our staff are available to our Customers.



ZECCHETTI AFTER-SALE SERVICE offers an immediate assistance "ON-LINE" via Modem.



## AIR conveyors



The quickest and most flexible way to transfer empty bottles from the Blow Moulder to the Palletizer.

- The high conveying speed allows:
  - a) a match with the production of whichever Blow Moulder
  - b) the use of the conveyor as a buffer.
- It represents the most effective system to split the bottle flow even on very-high speed lines.
- Thanks to its running principle, upslopes and downslopes can be realized without the necessity of additional equipments such as mechanical elevators/lowerators.

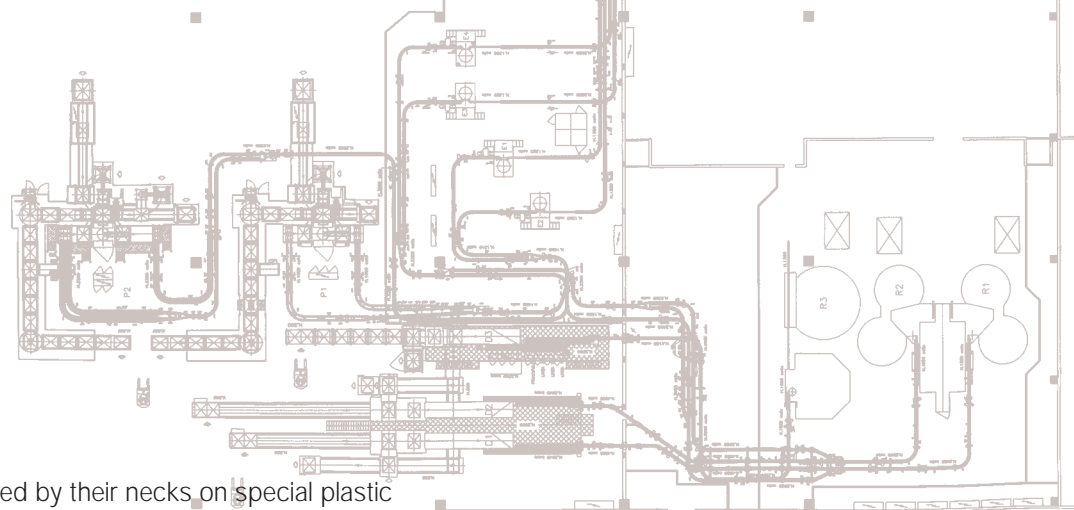

### Running principle.

Bottles are suspended by their necks on special plastic rails and are moved by air pressure produced by centrifugal fans. This principle guarantees absolute stability, a very high transfer speed, even behaviour of the various formats, absolute visibility and accessibility.



### Guide Adjustment

Both neck and body/shoulder guides can be either manually or automatically adjusted to accommodate different bottles sizes.

### Filtering Systems

Different filtering arrangements are available, dependent upon layout configuration and the customers requirements.



Standard Filtering  
1-stage

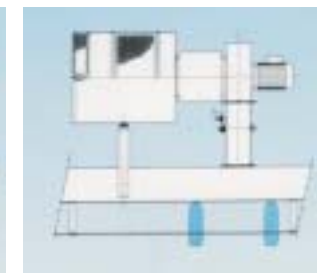

High Efficiency Filtering  
2-stages

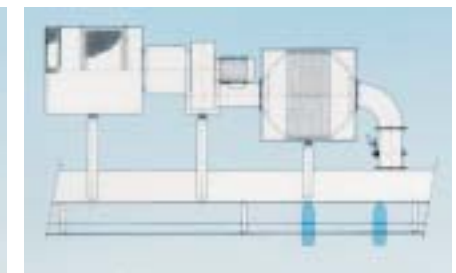

Very-High Efficiency Filtering  
3-stages

### Particulars



Bottle dump gate.

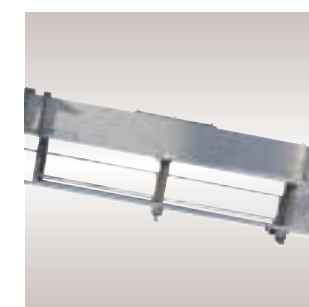

Section adjustable in height.



Splitter unit.

### Uses

Are various and suit both simple and particularly sophisticated lines. It may include labellers, testers, by-passes, direct connections to fillers, transfers between various lines. It is possible to connect: Blow Moulder - Palletizer, Depalletizer - Filler, Blow Moulder - Filler.

### Construction

- Frames are in STAINLESS STEEL and access is achieved using lids with latch closures and airtight seal.
- Bottle side guides (whose number is determined according to the bottle formats) are easily adjustable either manually or automatically and are made of anti-scratch brushes.
- Centrifugal fans are provided with filter, silencer and ON-OFF switch. The air pressure of every individual fan is determined by inverter controlled motors. Different running parameters can be selected directly from the operator panel.



## CHAIN conveyors

Chain conveyors are made of stainless steel.

Various kinds of chains, belts and lateral guides are used, depending on the bottle to be handled and the conveyor function.

Driven units are almost always controlled by inverter units, which are controlled by the signals they receive from the detectors installed along the line on the basis of the conditions set in the operator control panel. Adjusting the speed of the conveyors to suit circumstances.

**Such an individual control guarantees** efficient and safe handling of the product.



### Efficient and safe handling of the product

### High Transfer Speed

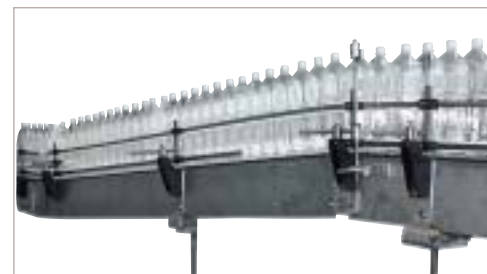

Several kinds of splitter and combiner unit allow the product to be directed towards the various areas of the line or to the palletizer infeed.

In particular, the "CONTINUOUS FLOW" Splitter Units contribute to very safe product handling, even at High Transfer Speeds.

When necessary, a "vacuum" system is added to the chain conveyors, to further increase the product stability, particularly at the critical zones.



### Product Stability

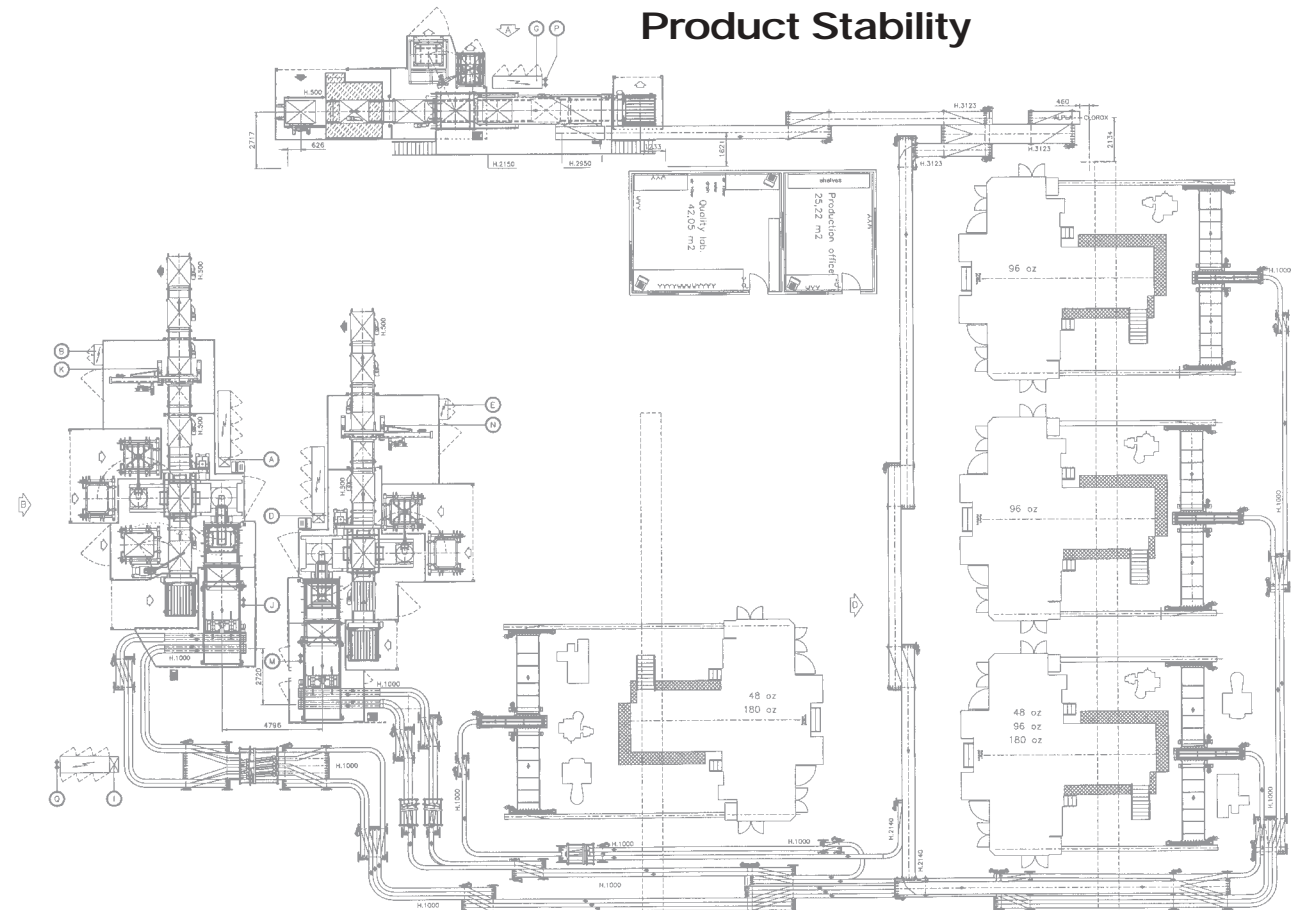

## "COLUMN" Type Empty Bottle Palletizer

Perfect tiers, without voids, are guaranteed by the row-by-row layer preparation system. An operator is not needed on fully automatic machines to reach peak efficiencies.



The Column Palletizer is a system based on a rotating column supporting the layer pick up head. The layer of bottles is taken from the forming table, at low level, and deposited onto the pallet. The layer centering system together with the independent sheet placement column enables the machine to handle different types of layer separator to assemble whichever pallet configuration (tier sheets / trays / inverted trays / top frames / with final strapping and or stretch wrapping).

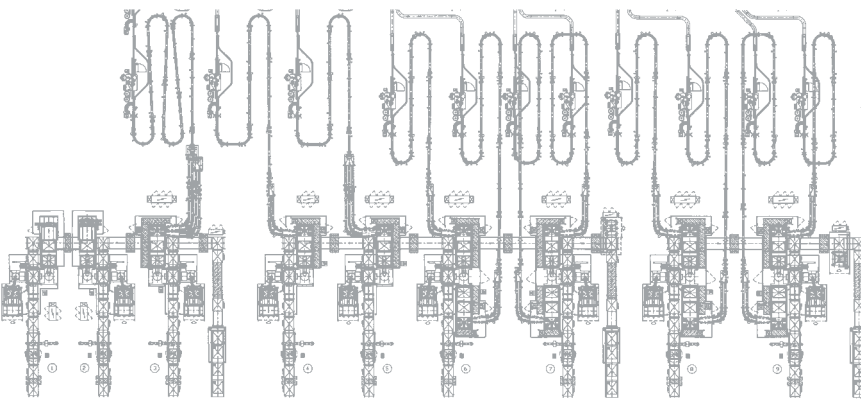

Easy Use and Maintenance  
– Low level machines enable a quick access for maintenance and and easy change-over.

The modular construction enables different levels of automation to be offered to cope with a wide range of speeds, from low to the very high-production speeds.

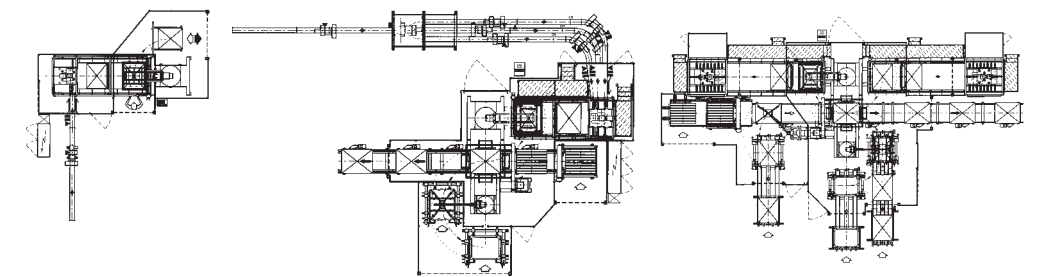

Semi-Automatic Palletizer

Medium-Speed Palletizer  
Single Table

High-Speed Palletizer  
Twin-Table

All kinds of bottles can be palletized thanks to the wide variety of pick-up systems available.



Pincher-rail  
pick-up head



Pressure  
pick-up head



Side gripping  
pick-up head



Zecchetti Supervising  
Application on Color Touch  
Screen Industrial PC.  
– Such an easy interface makes  
the operator's job even easier.

### Functions:

- Execution of the manual commands.
- Axis data management.
- Alarm diagnostic with visualization of the area where the alarm is + alarm description.
- Alarm history and statistics.
- Possibility of saving production recipes (type of bottle – pattern – layers/pallet, etc.)
- Possibility of modifying the line parameters.

### Characteristics:

- Easy to use through menus.
- On-line help on every page.
- Software easy to update.
- Immediate commands through the simple touch of the screen.
- 4 User levels.



## Details of bottle INFEEED SYSTEMS

### DROP ARM SYSTEM FROM THE AIR CONVEYOR

When arriving from the air conveyor, bottles are fed "row-by-row", in the correct number, to the DROP ARM SYSTEM which lowers them and releases the rows onto the layer forming table. The correct and complete formation of each layer without any voids, is guaranteed.

Several versions of the drop arm system are available, depending on the line speed: from the simple "1-lane" pneumatic system up to the "intelligent 4+4-lane" servocontrolled one.

Simple or fully automatic adjustments allow for very quick change-over.



### STACKER SYSTEM FROM THE CHAIN CONVEYOR

When bottles are transported with chain conveyors, the layer formation is carried out by pushing the rows from the infeed conveyors to the layer forming table.

The number of bottles forming every row being counted by photocells fitted on the same conveyors.



The layer correct and complete formation, without any voids, is guaranteed.

**PUSHER** movements and conveyor speed are inverter controlled. This, together with the very accurate construction, assures a fast and safe product handling. Several versions of stackers are available, according to the line speed and the bottle type. When required by a particularly unstable product, a "vacuum" system is applied to the stacker chains.

## "GANTRY" Type Empty Bottle Palletizer



MAXIMUM SPEED MACHINE

The machine works with **2** palletizing heads at the same time, thus palletizing **2** pallets simultaneously. The heads pick the layers up from **2** forming tables at low level, and transfer them, using a horizontal, telescopic transfer trolley, to the pallets. The GANTRY type Palletizer features all the characteristics of the COLUMN type machine, in terms of accessibility and modular construction.

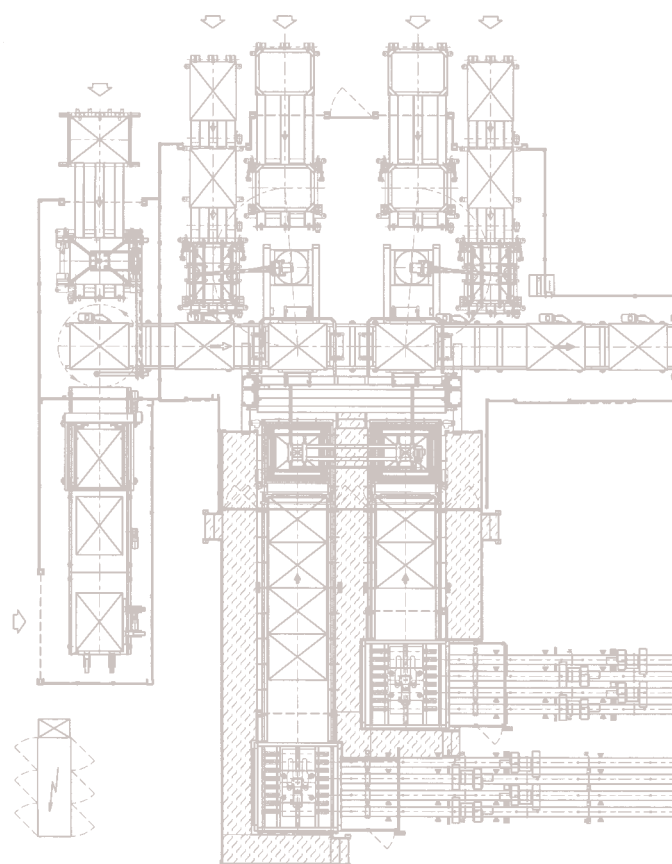



## PAL/DEPAL Combination "PDP"

The combination machine is suitable for carry-out the following functions:

- To provide top up to filling line via depalletizing table.
- To palletize the total output of the Blow-Moulder when filling operation is not taking place.

- To work in either palletizing or depalletizing mode, as appropriate, in the event of a failure in either the Blow Moulder or the Filling Line.

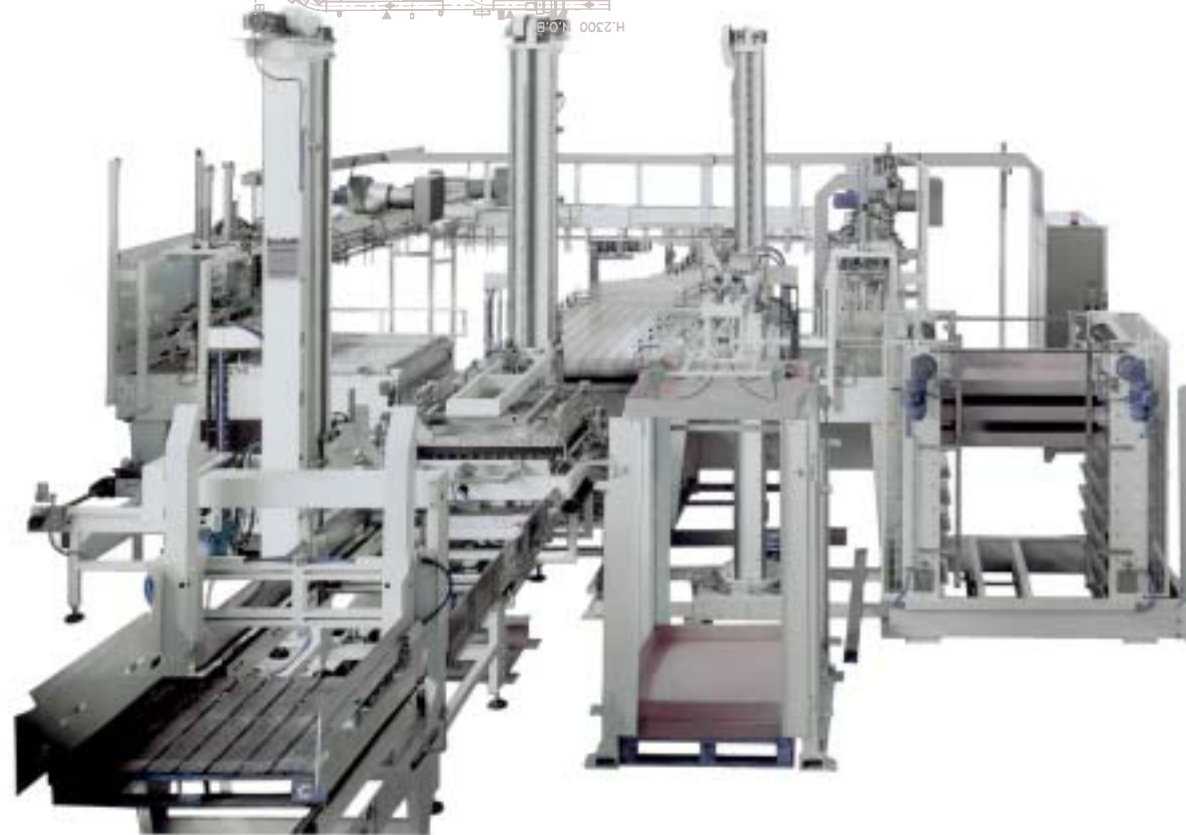
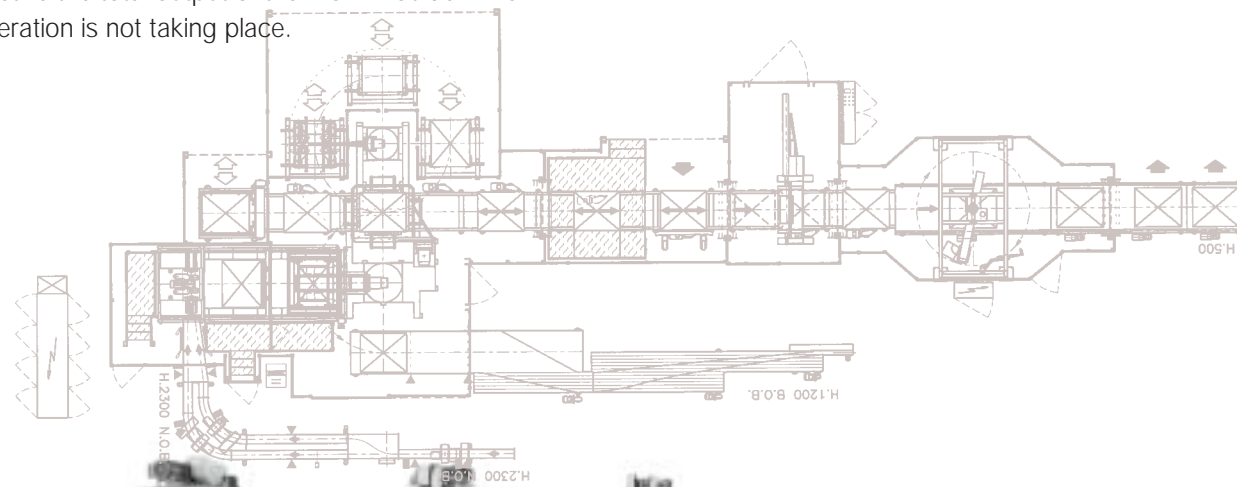

## High-Speed Depalletizer



### SWEEP-OFF Type HIGH-LEVEL Discharge

The layer is transferred by means of a lateral sweep arm from the pallet lifter housing, directly to the depalletizing table, at high level.

The inverter controlled movements and the fixed discharge level allow the machine to reach high depalletizing speeds in a very efficient manner.

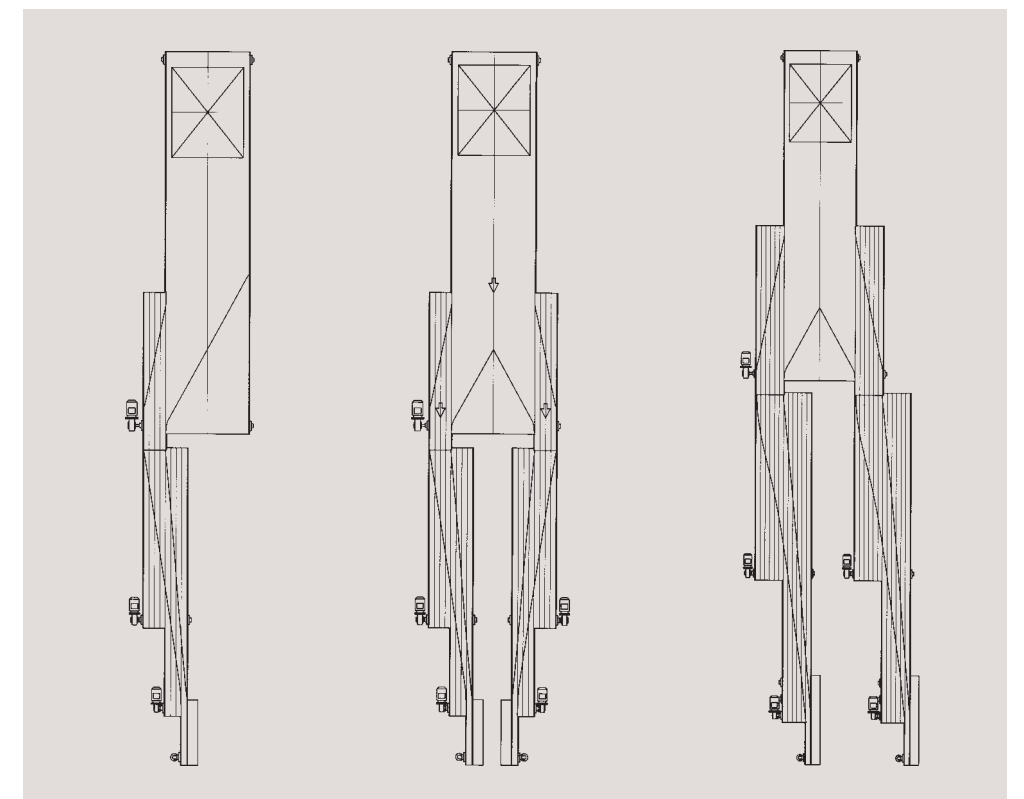

## Down Stream Equipment



AUTOMATIC VERTICAL STRAPPER  
(2 straps)



AUTOMATIC VERTICAL STRAPPER  
(2 + 2 straps)



AUTOMATIC ROTARY ARM STRETCH WRAPPER



AUTOMATIC TRAY ERECTOR  
(for Pinned Trays or with Hot Melt)

